

Exam 1

Wednesday, Sep 23, 2009, BEL 328, 6:00-8:00 pm

1. A particle is moving in a straight line with an acceleration $a(t) = c(t-2)^2$, where c is a positive constant. At the time $t_0 = 2$, the corresponding position and velocity are x_0 and v_0 , respectively. Derive the formulas for position $x(t)$ and velocity $v(t)$ at any time t (5 points)

$$a = \dot{v} = c(t-2)^2 \quad \int dt$$

$$v(t) \Big|_2^t = \frac{c}{3} (t-2)^3 \Big|_2^t$$

$$v(t) - v_0 = \frac{c}{3} (t-2)^3 \Rightarrow v(t) = v_0 + \frac{c}{3} (t-2)^3 \quad \int dt$$

$$x(t) \Big|_2^t = \left[v_0 t + \frac{c}{12} (t-2)^4 \right] \Big|_2^t$$

$$x(t) - x_0 = v_0(t-2) + \frac{c}{12} (t-2)^4$$

$$x(t) = x_0 + v_0(t-2) + \frac{c}{12} (t-2)^4$$

2. At point $r = 2\text{m}$, $\theta = 30^\circ$, the cylindrical components of the acceleration vector of a particle at the point are $a_r = 2$, $a_\theta = -1$ [m/s²]. Calculate the Cartesian components a_x, a_y of the acceleration vector. (5 points)

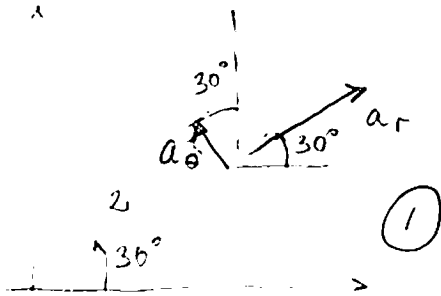

$$a_x = a_r \cos 30^\circ - a_\theta \sin 30^\circ$$

$$= 2 \cdot \frac{\sqrt{3}}{2} + 1 \cdot \frac{1}{2} = 2.232 \left[\frac{\text{m}}{\text{s}^2} \right]$$

$$a_y = a_r \sin 30^\circ + a_\theta \cos 30^\circ$$

$$= 2 \cdot \frac{1}{2} + (-1) \frac{\sqrt{3}}{2} = 0.134 \left[\frac{\text{m}}{\text{s}^2} \right]$$

actual situation:

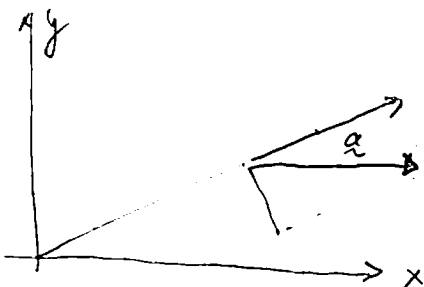

3. Derive the Frenét formulas for the velocity and acceleration vectors. (5 points)

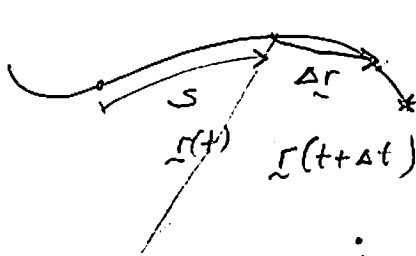

$$\vec{v} = \lim_{\Delta t \rightarrow 0} \frac{\Delta \vec{r}}{\Delta t} = \lim_{\Delta t \rightarrow 0} \left(\frac{\Delta \vec{r}}{\Delta s} \cdot \frac{\Delta s}{\Delta t} \right)$$

$$= \dot{s} \frac{d\vec{r}}{ds} = \dot{s} \vec{e}_t \quad (2)$$

$$\vec{a} = \dot{\vec{v}} = \ddot{s} \vec{e}_t + \dot{s} \frac{d\vec{e}_t}{ds} \cdot \dot{s}$$

$$= \ddot{s} \vec{e}_t + \frac{\dot{s}^2}{\rho} \vec{e}_n \quad (3)$$

$\underbrace{\ddot{s}}_{a_t} \quad \underbrace{\frac{\dot{s}^2}{\rho}}_{a_n}$

4. Derive the formulas for acceleration vector components a_r, a_θ, a_z in the cylindrical system of coordinates (5 points)

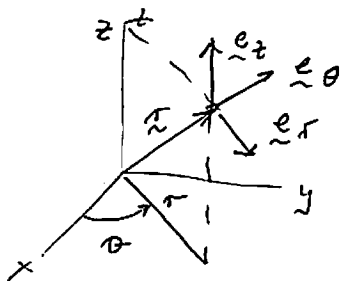

$$\vec{r} = r \vec{e}_r + z \vec{e}_z$$

$$\vec{v} = \dot{\vec{r}} = \dot{r} \vec{e}_r + r \frac{d\vec{e}_r}{d\theta} \dot{\theta} + \dot{z} \vec{e}_z$$

$$= \dot{r} \vec{e}_r + r \dot{\theta} \vec{e}_\theta + \dot{z} \vec{e}_z \quad (2)$$

$$\vec{a} = \dot{\vec{v}} = \ddot{r} \vec{e}_r + \dot{r} \frac{d\vec{e}_r}{d\theta} \dot{\theta} + \dot{r} \dot{\theta} \vec{e}_\theta + r \ddot{\theta} \vec{e}_\theta + r \dot{\theta} \frac{d\vec{e}_\theta}{d\theta} \dot{\theta} + \ddot{z} \vec{e}_z$$

$$= (\ddot{r} - r\dot{\theta}^2) \vec{e}_r + (r\ddot{\theta} + 2\dot{r}\dot{\theta}) \vec{e}_\theta + \ddot{z} \vec{e}_z$$

$\underbrace{\quad}_{a_r} \quad \underbrace{\quad}_{a_\theta} \quad \underbrace{\quad}_{a_z}$

$$\vec{e}_r = (\cos \theta, \sin \theta, 0)_{a_r}$$

$$\frac{d\vec{e}_r}{d\theta} = (-\sin \theta, \cos \theta, 0) = \vec{e}_\theta \quad (3)$$

$$\frac{d\vec{e}_\theta}{d\theta} = (-\cos \theta, -\sin \theta, 0) = -\vec{e}_r$$

5. A particle moves along a parabola $y = x^2$ with a constant speed v . Determine the Cartesian components of the velocity vector as a function of coordinate x . (5 points)

$$y = x^2$$

$$\dot{y} = 2x \dot{x}$$

$$v^2 = \dot{x}^2 + \dot{y}^2 = \dot{x}^2 + 4x^2 \dot{x}^2 = \dot{x}^2 (1 + 4x^2)$$

$$\therefore \dot{x} = \pm \frac{v}{\sqrt{1+4x^2}}$$

$$\dot{y} = \pm \frac{2xv}{\sqrt{1+4x^2}} \quad (5)$$

Constrained motion problem

6. If the pitching wedge the golfer is using gives the ball an initial angle $\theta_0 = 50^\circ$, what range of velocities v_0 will cause the ball to land within 3 ft of the hole (Assume that the hole lies in the plane of the ball's trajectory.) (25 points)

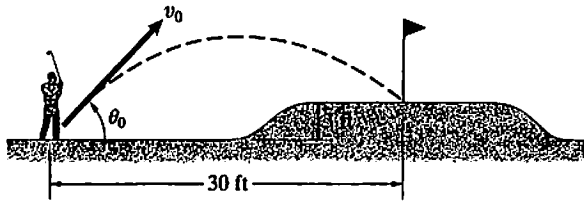

Case: ball hits a point 3 ft left to the hole

$$(5) \begin{cases} x = v_0 \cos 50^\circ t = 27 & \Rightarrow t = \frac{27}{v_0 \cos 50^\circ} \\ y = v_0 \sin 50^\circ t - 32.2 \frac{t^2}{2} = 3 & = \frac{42}{v_0} \end{cases}$$

$$v_0 \cdot 0.766 \frac{42}{v_0} - 16.1 \frac{42^2}{v_0^2} = 3$$

$$\frac{28400}{v_0^2} = 29.172$$

$$v_0 = 31.2 \left[\frac{\text{ft}}{\text{s}} \right]$$

(10)

Case: ball hits a point 3 ft right to the hole

$$x = v_0 \cos 50^\circ t = 33 \quad \Rightarrow t = \frac{33}{v_0 \cos 50^\circ} = \frac{51.34}{v_0}$$

$$y = v_0 \sin 50^\circ t - 32.2 \frac{t^2}{2} = 3$$

$$v_0 \cdot 0.766 \frac{51.34}{v_0} - 16.1 \frac{(51.34)^2}{v_0^2} = 3$$

$$\frac{42436.3}{v_0^2} = 36.326$$

$$v_0 = 34.18 \left[\frac{\text{ft}}{\text{s}} \right]$$

(10)

The initial speed must be in the range

$$\underline{31.2 \leq v_0 \leq 34.18 \frac{\text{ft}}{\text{s}}}$$

7. The collar A slides on the circular bar. The radial position of A (in meters) is given as a function of θ by $r = 2 \cos \theta$. At the instant shown, $\theta = 25^\circ$, $\dot{\theta} = 4$ [rad/s] and $\ddot{\theta} = 0$. Determine the velocity and acceleration of A in terms of polar coordinates. (25 points)

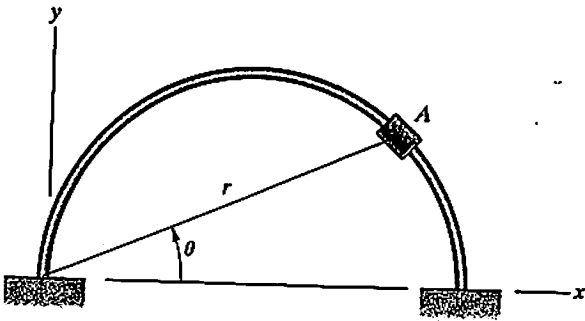

$$r = 2 \cos \theta = 1.813 \text{ [m]}$$

$$\frac{dr}{d\theta} = -2 \sin \theta = -0.845 \text{ [m/r]}$$

$$\frac{d^2r}{d\theta^2} = -2 \cos \theta = -1.813 \text{ [m/r^2]}$$

$$v_r = \dot{r} = \frac{dr}{d\theta} \dot{\theta} = -0.845 \cdot 4 = -3.38 \text{ [m/s]}$$

$$v_\theta = r \dot{\theta} = 1.813 \cdot 4 = 7.252 \text{ [m/s]}$$

10

$$a_r = \ddot{r} - r \dot{\theta}^2$$

$$\begin{aligned} \ddot{r} &= \frac{dr}{dt} = \frac{d}{dt} \left(\frac{dr}{d\theta} \dot{\theta} \right) = \frac{d^2r}{d\theta^2} \dot{\theta}^2 + \frac{dr}{d\theta} \ddot{\theta} \\ &= -1.813 \cdot 16 = -29 \text{ [m/s}^2\text{]} \end{aligned}$$

$$a_r = \ddot{r} - r \dot{\theta}^2 = -29 - 1.813 \cdot 16 = -58 \text{ [m/s}^2\text{]}$$

15

$$a_\theta = r \ddot{\theta} + 2 \dot{r} \dot{\theta} = 2 \cdot (-3.38) \cdot 4 = -27.04 \text{ [m/s}^2\text{]}$$

8. The car increases its speed at a constant rate from 40 mi/h at A to 60 mi/h at B. Determine the magnitude of its acceleration when it has traveled along the road a distance 120 ft from A (1 mi = 5280 ft). (25 points)

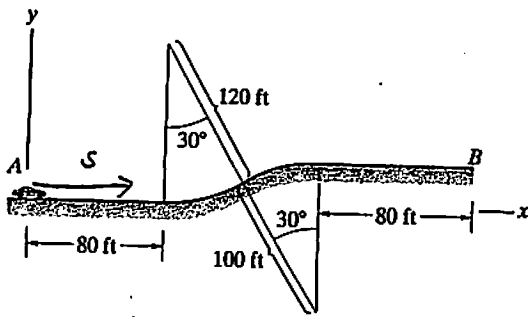

$$v_A = 40 \frac{\text{mi}}{\text{h}} = 40 \frac{5280}{3600} = 58.67 \left[\frac{\text{ft}}{\text{s}} \right]$$

$$v_B = 60 \frac{\text{mi}}{\text{h}} = 88 \left[\frac{\text{ft}}{\text{s}} \right]$$

distance from A to B, i.e.

$$s_B = 80 + \frac{30}{180} \pi \cdot 120 + \frac{30}{180} \pi \cdot 100 + 80 = 275.2 \text{ [ft]} \quad (5)$$

$$\int_0^{275.2} a_t ds = \int_{58.67}^{88} v dv$$

$$a_t \cdot 275.2 = \frac{v^2}{2} \Big|_{58.67}^{88} = 2150.9$$

$$a_t = 7.815 \left[\frac{\text{ft}}{\text{s}^2} \right] \quad (10)$$

at $s = 120$ ft, the car is within the first circular segment, where $\rho = 120$ ft

$$\int_0^{120} a_t ds = \int_{58.67}^v v dv = \frac{1}{2} (v^2 - 58.67^2)$$

$$937.8 \quad v = 72.92 \left[\frac{\text{ft}}{\text{s}} \right]$$

$$a_n = \frac{v^2}{\rho} = \frac{72.92^2}{120} = 44.315 \left[\frac{\text{ft}}{\text{s}^2} \right] \quad (10)$$

$$a = \sqrt{a_t^2 + a_n^2} = \sqrt{7.815^2 + 44.315^2} = 45 \left[\frac{\text{ft}}{\text{s}^2} \right]$$